

Einbauanleitung  
Mounting instruction  
Montagehandleiding  
Instructions de montage  
Istruzioni di montaggio

Sturotec D Mini XL

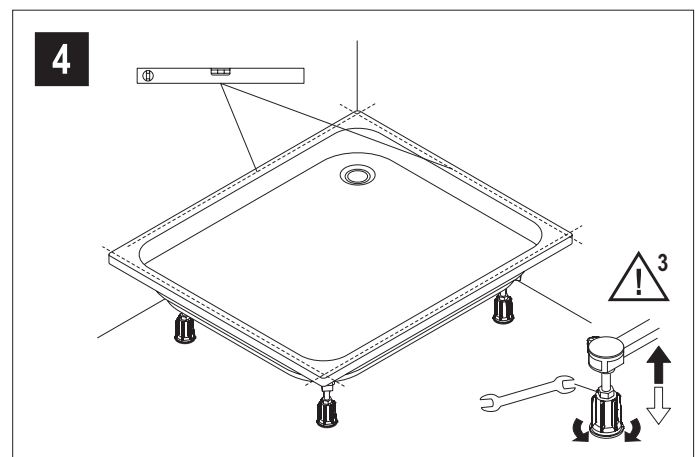
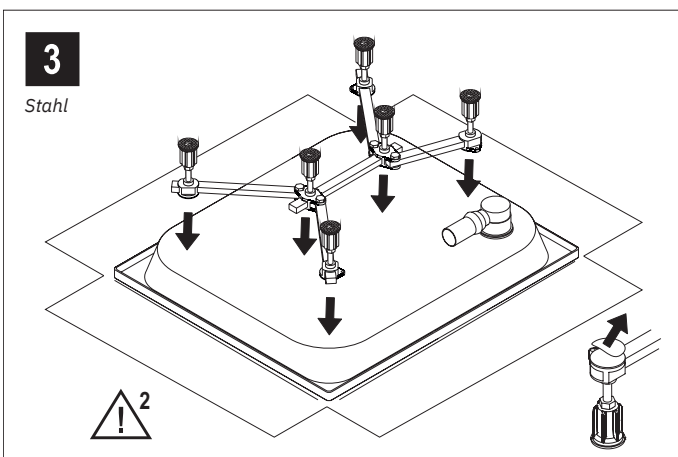
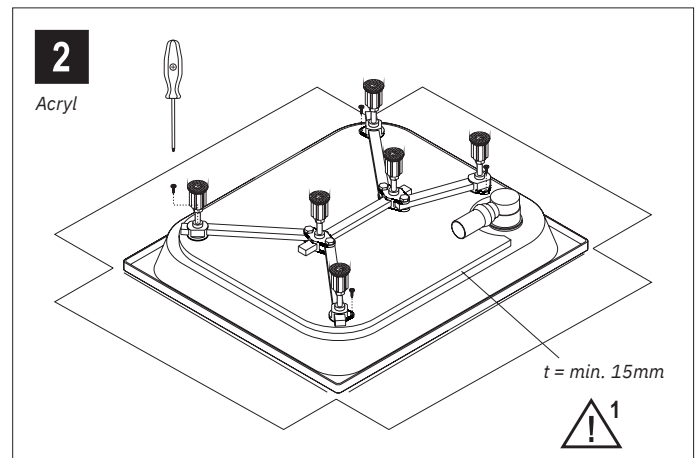
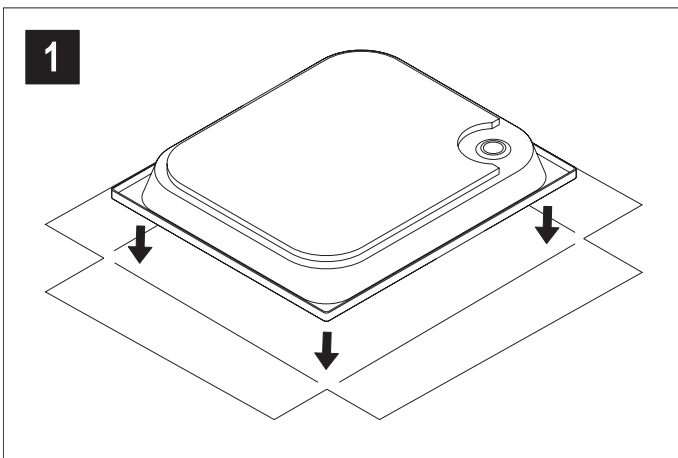
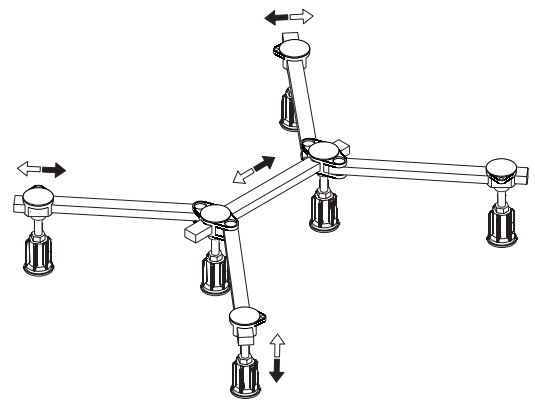
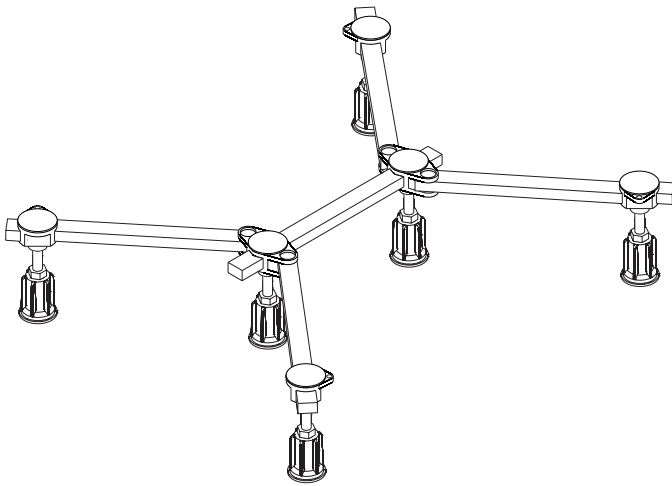

Einbauanleitung  
Mounting instruction  
Montagehandleiding  
Instructions de montage  
Istruzioni di montaggio

Sturotec D Mini XL

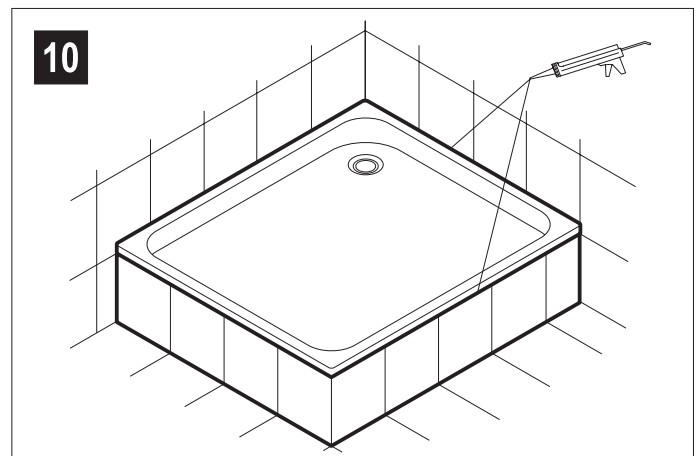
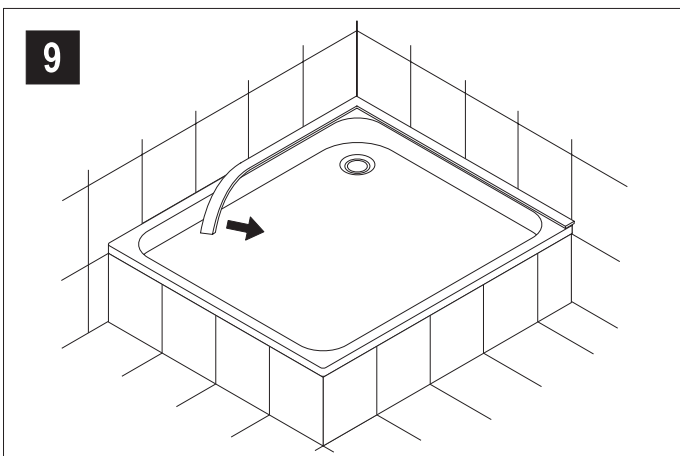
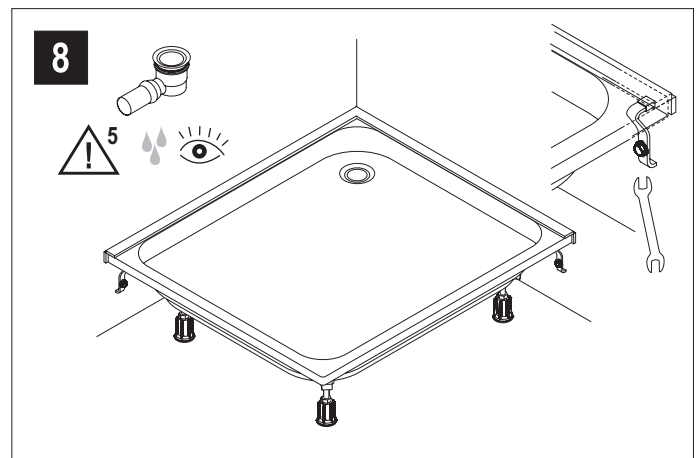
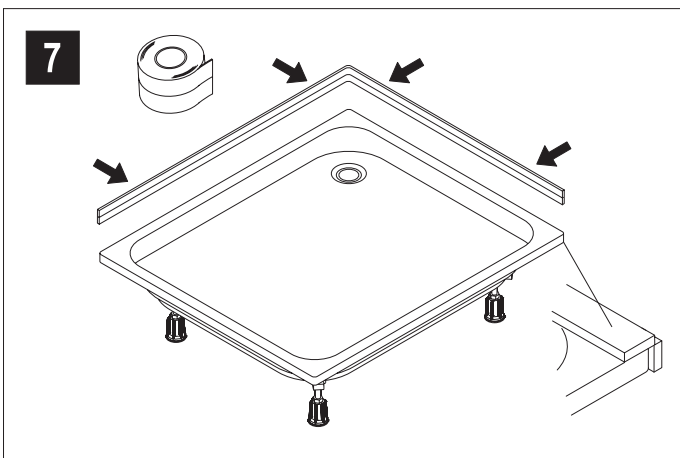
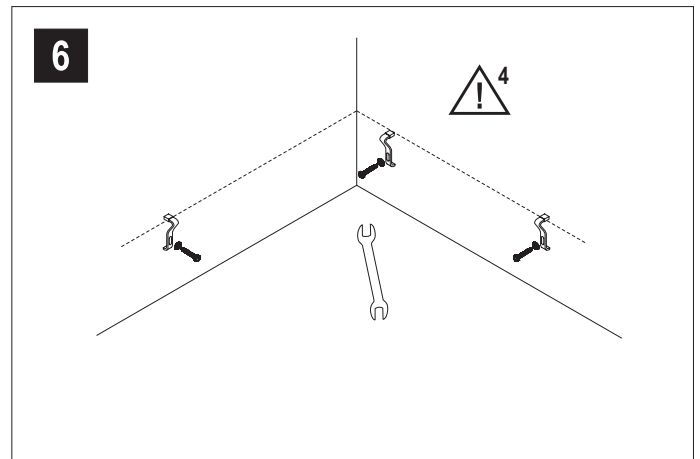
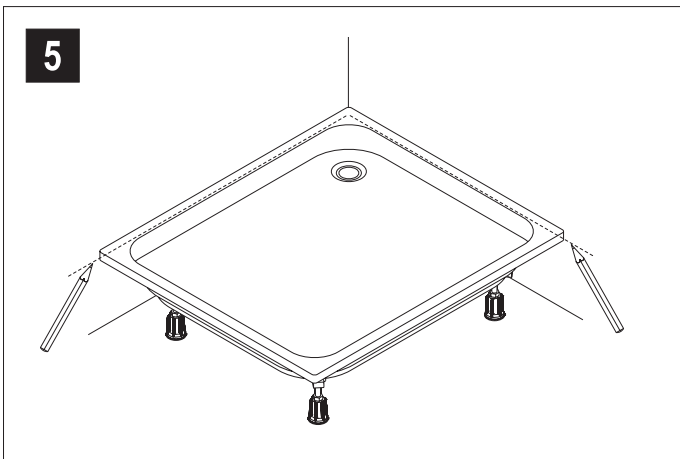

## Einbauanleitung Mounting instruction Montagehandleiding Instructions de montage Istruzioni di montaggio

Sturotec D Mini XL

### Verwendung:

- Für den Einbau muss ein ebener, tragfähiger, schwingungsfreier Untergrund vorhanden sein.
- Für Stahl- und Acrylduschwannen von 750 × 750 mm bis 1200 × 1200 mm quadratisch und 750 × 750 mm bis 1500 × 900 mm rechteckig



Die einschlägigen Verarbeitungsrichtlinien aller beteiligten Gewerke sind zu berücksichtigen.



**1** Acrylduschwannen: Die Schraubenlänge ist zu beachten. Der Wannenerboden muss mindestens 15 mm stark sein.



**2** Stahlduschwannen: Der Wannenerboden muss für das Aufkleben der Standfüße frei von Staub, Schmutz, Wasser und Fettrückständen sein.



**3** Nach dem Ausrichten der Duschwanne die höhenverstellbaren Füße mit der Sechskantmutter gegen erneutes Verstellen sichern.



**4** 2 Wannenerandklemmstücke + 1 Wannenerandklemmleiste/Wannenerandauflegeleiste oder 3 Wannenerandklemmstücke bis zu einer Duschwannengröße von 1000 × 1000 mm.



**5** Nach Installation der Ablaufgarnitur ist eine Dichtigkeitsprüfung durchzuführen.

### Use:

- For installation, a flat, firm, vibration-free foundation is required.
- For steel and acrylic shower trays from 750 × 750 to 1200 × 1200 mm square and from 750 × 750 mm to 1500 × 900 mm rectangular



The relevant processing guidelines of all trades involved are to be considered.



**1** Acrylic shower trays: The screw length has to be observed. The tray floor bottom should be at least 15 mm in thickness.



**2** Steel shower trays: For cementing the supporting feet in place, the tray floor bottom should be free from dust, dirt, water and grease residues.



**3** After alignment of the shower tray, lock the height-adjustable feet by the hexagon nut against misadjustment.



**4** 2 tray rim clamping piece + 1 tray rim clamping strip/tray rim supporting strip or 3 tray rim clamping pieces for a shower tray size of up to 1000 × 1000 mm.



**5** After installation of the drain fitting, a leak test is to be carried out.

## Einbauanleitung Mounting instruction Montagehandleiding Instructions de montage Istruzioni di montaggio

Sturotec D Mini XL

### Toepassing:

- Voor de montage moet een vlakke, stevige, trillingsvrije ondergrond aanwezig zijn.
- Voor stalen en acryl douchebakken van 750 × 750 t/m 1200 × 1200 mm vierkant en van 750 × 750 mm t/m 1500 × 900 mm rechthoekig



De relevante verwerkingsrichtlijnen voor alle betrokken gespecialiseerde werkzaamheden dienen in acht te worden genomen.



**1** Acryl douchebakken: De schroeflengte moet worden in acht genomen. De vloer onder de douchebak moet tenminste 15 mm dik zijn.



**2** Stalen douchebakken: De vloer onder de douchebak moet voor het opplakken van de pootjes vrij zijn van stof, vuil, water en vetresten.



**3** Na het uitlijnen van de douchebak moeten de in hoogte verstelbare pootjes met de zeskantmoer tegen opnieuw verstellen worden geborgd.



**4** 2 bakrandklemstuk + 1 bakrandklemstrip/bakranddraagstrip of 3 bakrandklemstukken tot een douchebakmaat van 1000 × 1000 mm.



**5** Na installatie van het afvoergarnituur dient een lektest te worden uitgevoerd.

### Utilisation :

- Pour l'installation, il faut une surface plate, portante et sans vibration.
- Pour bacs de douche en acier et acrylique de 750 × 750 à 1200 × 1200 mm carré et de 750 × 750 mm à 1500 × 900 mm rectangulaire



Les directives de traitement en vigueur pour tous les corps de métiers engagés doivent être respectées.



**1** Bacs de douche en acrylique: la longueur de la vis doit être respecté. Le fond du bac doit avoir au moins 15 mm d'épaisseur.



**2** Bacs de douche en acier: le fond du bac ne doit comporter ni poussière, ni saleté, ni eau, ni résidu de graisse pour pouvoir coller les pieds.



**3** Après le dressage du bac de douche, bloquer les pieds réglables en hauteur avec l'écrou si pans pour éviter tout dérèglement.



**4** 2 crochets fixation de baguette d'appui + 1 baguette de blocage/baguette d'appui de bordure de bac ou 3 crochets de fixation de baguette d'appui jusqu'à une dimension de bac de douche de 1000 × 1000 mm.



**5** Après installation de la garniture d'écoulement, il faut contrôler l'étanchéité.

## Einbauanleitung Mounting instruction Montagehandleiding Instructions de montage Istruzioni di montaggio

Sturotec D Mini XL

### Utilizzo:

- Per il montaggio deve essere presente una superficie di appoggio piana, di portata sufficiente e senza vibrazioni.
- Per vasche doccia in acciaio ed in acrilico da 750 × 750 a 1200 × 1200 mm quadrato e da 750 × 750 mm a 1500 × 900 mm rettangolare

 È necessario osservare le direttive specifiche di lavorazione di tutti i sistemi interessati

 1 Vasche doccia in acrilico: la lunghezza di vite deve essere osservata. Il sottofondo della vasca deve essere spesso almeno 15 mm.

 2 Vasche doccia in acciaio: per poter incollare i piedi di appoggio, il sottofondo della vasca deve essere privo di polvere, sporco, acqua e residui di grasso.

 3 Dopo aver posizionato la vasca doccia, bloccare i piedi regolabili in altezza con i dadi esagonali per impedire che si spostino.

 4 2 elemento di bloccaggio del bordo della vasca + 1 listello di bloccaggio per il bordo della vasca/listello di appoggio per il bordo della vasca o 3 elementi di bloccaggio del bordo della vasca per vasche doccia fino a 1000 × 1000 mm.

 5 Dopo aver installato l'elemento di scarico è necessario eseguire un controllo della tenuta.

## Einbauanleitung Mounting instruction Montagehandleiding Instructions de montage Istruzioni di montaggio

Sturotec D Mini XL

Empfohlenes Zubehör / Recommended accessories /  
Aanbevolen toebehoren / Accessoires recommandés /  
Accessori raccomandati:

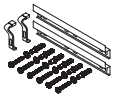

Wannenrandklemmleisten  
Tray rim clamping strips  
Bakrandklemstrips  
Baguettes de blocage bordure de bac  
Listelli di bloccaggio per il bordo della vasca

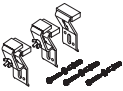

Wannenrandklemmstück  
Tray rim clamping piece  
Bakrandklemstuk  
Crochets fixation de baguette d'appui  
Elemento di bloccaggio del bordo della vasca



Zur Körperschallentkopplung von Stahl- und Acrylwan-  
nen zur Wand  
For acoustic decoupling of steel and acrylic trays from  
the wall  
voor geluidsisolatie van stalen en acryl bakken t.o.v. de  
muur  
Pour l'isolation phonique des bacs en acier et en acry-  
lique contre le mur  
Per il disaccoppiamento acustico tra vasche in acciaio  
ed in acrilico e la parete



Zur Körperschallentkopplung von Stahl- und Acrylwan-  
nen zur Ab-/Ummauerung  
For acoustic decoupling of steel and acrylic trays from  
the lining/surround  
Voor geluidsisolatie van stalen en acryl bakken t.o.v. de  
ombouw  
Pour l'isolation phonique des bacs en acier et en acry-  
lique contre le muret de pourtour  
Per il disaccoppiamento acustico tra vasche in acciaio  
ed in acrilico e la muratura sottostante/perimetrale